

Aerospace Fasteners: Use in Structural Applications

George Nadim Melhem

*School of Materials Science and Engineering, University of New South Wales, Sydney,
NSW 2052 Australia: Perfect Engineering Pty Ltd, 14 Dick St, Henley, NSW 2111*

Abstract

Aircraft components need to be selected and manufactured to adequately combat the environment, temperature, loading, compatibility, and so on. When structural materials such as aluminum alloys or fiber-reinforced polymer composites need to be joined in aircraft, the selection of fasteners, bolts, rivets, adhesives, and other methods need to be quantitatively assessed in order that the correct design for the component and joining method is identified. There is a variety of fasteners, bolts, and rivets, made using a variety of materials. Aluminum rivets are often used to join aluminum components in an aircraft. Rivets do not perform well under tension loading, but perform better in shear, thus limiting the application specifically for these purposes. Bolts are designed to clamp material together, and even though the bolt may be adequate to support a particular structure and load requirement, consideration must also be given to the modulus of elasticity and stiffness of the components that are being clamped together. Therefore, an understanding of each of the materials being clamped or joined together is necessary. Bolts manufactured from steel, for instance, have coatings applied in order to help protect them from corrosion. The use of composites translates to a reduced number of rivets and fasteners to be used. Drilling of holes into composites to insert fasteners poses many challenges because the fibers are damaged, a region of high stress concentration may be formed, and the hole is a site for the ingress of water or moisture. The insertion of aluminum fasteners or the contact of aluminum components with carbon fibers creates galvanic corrosion due to the large difference in electrical potential. Titanium alloy (Ti-6Al-4V) is a typical fastener where there is composite joining due to its better compatibility (elimination of galvanic corrosion) and increased strength properties. Substitution of rivets and fasteners for welding is also on the increase in aircraft because laser beam welding (LBW) and friction stir welding both reduce cracking, porosity, and better properties achieved due to deeper penetration, and reduce the heat-affected zone which would typically be undesirable with conventional arc welding such as metal inert gas and tungsten inert gas welding. The shear and compressive stresses are increased, and fatigue cracking, weight, and cost are also reduced as a result of LBW, including the elimination of stresses and corrosion associated with rivets and the elimination of adhesives. Dissimilar metals such as the 7000 series and the 2000 series can be joined with a filler metal compatible to both metals to mitigate galvanic corrosion.

Keywords: Aircraft; Bolts; Galvanic corrosion; Rivets.

REQUIREMENTS TO PUSH THE ENVELOPE IN MATERIALS

A myriad of factors must be considered when designing aircraft, with some of the most important being structural safety, longevity, weight, fuel efficiency, and cost. An aerospace engineer can potentially choose from over 120,000 different materials for use in the airframe or engine. However, typically less than 100 different materials are suitable for most aerospace structures.^[35] The main reason for this limited number is due to the stringent property requirements for aircraft material to be lightweight, stiff, strong, fatigue resistant, toughness, damage tolerant, durable, easy to manufacture, and cost-effective. The majority of

the materials are therefore ruled out as a result of these mandatory properties.

Aircraft structural materials used in major components such as the fuselage, wings, landing gear, and empennage are subject to a range of loading/forces. For example, an aircraft fuselage is subjected to various forces including compression, tension, bending torsion and pressurization as it is carrying the entire payload. As another example, the upper surface of an aircraft wing is subjected to compression and the lower surface to tension during flight. Figure 1 shows that 2024 and 7075 aluminum alloys are used in the upper wing skins and stringers as they have a good combination of the following properties: compressive yield strength, modulus, fatigue, fracture toughness,

Fuselage skin	: 2024-T3, 7075-T6, 7475-T6
Fuselage stringers	: 7075-T6, 7075-T73, 7475-T76, 7150-T77
Fuselage frames/bulkheads	: 2024-T3, 7075-T6, 7050-T6
Wing upper skin	: 7075-T6, 7150-T6, 7055-T77
Wing upper stringers	: 7075-T6, 7150-T6, 7055-T77, 7150-T77
Wing lower skin:	: 2024-T3, 7475-T73
Wing lower stringers	: 2024-T3, 7075-T6, 2224-T39
Wing lower panels	: 2024-T3, 7075-T6, 7175-T73
Ribs and spars	: 2024-T3, 7010-T76, 7150-T77
Empennage (tail)	: 2024-T3, 7075-T6, 7050-T76

Material properties:

Corrosion

CYS = Compressive Yield Strength

E = Modulus

FAT = Fatigue

() = Important, but not critical, design requirement

FCG = Fatigue Crack Growth

FT = Fracture Toughness

SS = Shear Strength

TS = Tensile Strength

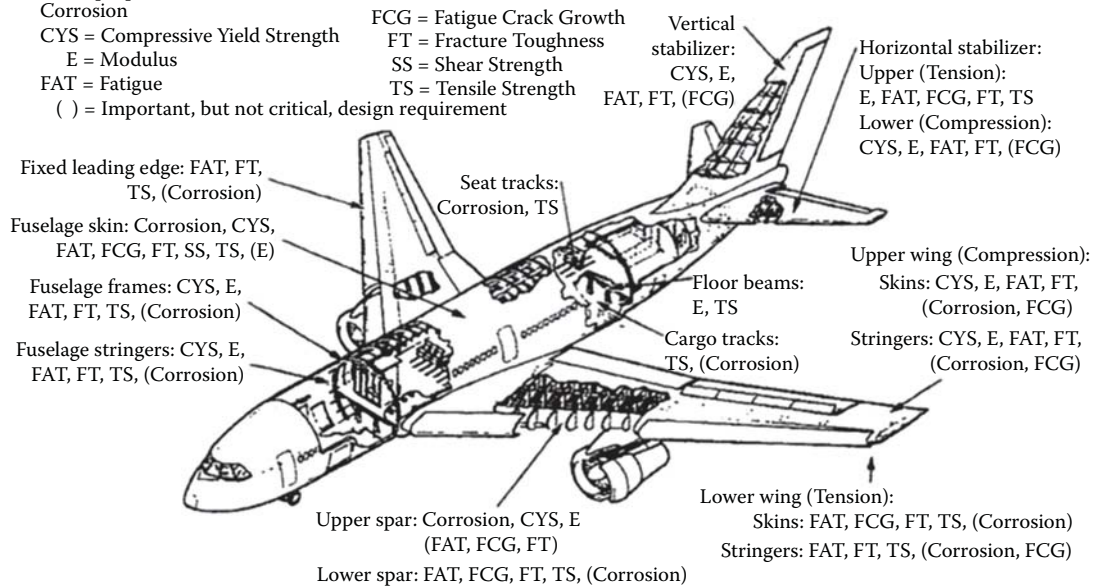

Fig. 1 Materials selection for structural members of a typical passenger aircraft^[39]

fatigue crack growth, and corrosion. The most commonly used aircraft structural materials are high-strength aluminum alloys, titanium alloys, and carbon fiber-reinforced polymer composites.

AEROSPACE FASTENERS: USE IN STRUCTURAL APPLICATIONS

The variables involved in the selection of fasteners to join aircraft components can be immense due to the assembly of an extremely large number of parts. Because aircraft are subjected to a variety of loads and design constraints, this necessitates a large number of components made of different materials/strengths. With the advancement of the aircraft and its design, consideration must be given to design for a myriad of metals and composites combined.

The challenges faced in aircraft construction range from incorrect design or lack of available information/knowledge/history, environmental factors, temperature, initial preload, fatigue, vibration, incorrect maintenance scheduling or incomplete/incorrect maintenance, undetected corrosion hidden beneath complex joints that are not easily accessible or exposed to rain for washout of debris, dissimilar materials

being joined to one another (metal/metal, metal/composite), incorrect heat treatment of metals or incorrect construction of composites (fiber orientation or manufacturing flaws), pilots incorrectly maneuvering aircraft and subjecting materials to stresses beyond their design capabilities, bird strike damage, lightning strikes, and so on.

There are many variables for the design engineer to consider before deciding upon the best means for joining structural components. The most common joining methods are adhesive bonding and mechanical fasteners such as bolts, rivets, and screws. Bolts can be selected from a variety of grades such as steel (e.g., carbon steel, stainless steel). Titanium and aluminum are also used as fasteners, although aluminum is not widely used due to its low yield stress and susceptibility to corrosion. Titanium (Ti-6Al-4V) fasteners are commonly used where diameters are less than ~19 mm, whereas many larger diameter fasteners are made of steel.

Steel is used for fasteners in landing gears, wing root, and wing attachments due to its very high strength, stiffness, and fatigue-resistant properties. Rivets are mostly manufactured from titanium, A286 stainless steel, and plain carbon steels. The head is easily formed by bucking, and they will not crack as they have good cold-forming properties. Most rivets have universal heads, but other typical head

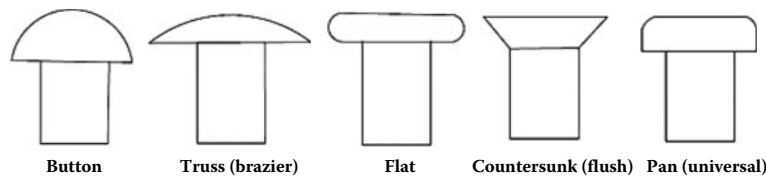

Fig. 2 Typical rivet heads—the United States^[4]

designs are shown in Fig. 2. Rivets should not be used for joining composites as they expand into an interference fit, and this may cause delamination damage around the hole.^[4] Table 1 lists the various types of fasteners, their grades, and their recommended application with certain materials for galvanic compatibility.

Huckbolts as shown in Fig. 3 have their stem broken in the position of the notch. These bolts are available in aluminum, stainless steel, and carbon steel. Generally, aircraft rivets are of aluminum alloy grade such as 5056, 2117, 2017, 2024, and 1100.

High-shear pin rivets (Fig. 4) are made from aluminum, stainless steel, titanium, or carbon steels. However, this type of rivet is only used for shear-loading purposes. Lightweight grooved proportioned lockbolt (Fig. 5) is manufactured with a titanium shank which has a high-shear capability and is typically used in joining composite materials. The extra-large sizes made for the heads and collars have been designed intentionally in this manner in order to minimize stresses on the composite material.

FASTENERS USED FOR THE ASSEMBLY OF AIRCRAFT COMPONENTS

Blind fasteners differ from rivets in that only one side is easy to access.^[26] Threaded fasteners are easily removed even after assembly without any damage to the fastener. Pin fasteners may be either tubular or solid and are used primarily where shear is the dominant load. Most aircraft structures require fasteners that may be used in combination with adhesives. Most of the above-mentioned fasteners can be used in composite joints such as rivets, pins, bolts, and blind fasteners (see Table 1).

THREADED FASTENER DESIGN FOR AIRCRAFT

Fasteners can generally be categorized into two main types: (1) tensioned fasteners with a threaded nut are designated as bolts, and (2) the other type has a dependence upon the bolt shank tensile strength which is applied to clamp the material

Table 1 Applications of various composite materials with various fastener types^[26]

Fastener type	Fastener material	Surface coating	Suggested application			
			Epoxy/graphite composite	Kevlar	Fiberglass	Honeycomb
Blind rivets ^a	5056 aluminum	None	Not recommended ^b	Excellent ^b	Excellent ^b	^c
	Monel	None	Good ^b	Excellent ^b	Excellent ^b	^c
	A-286	Passivated	Good ^b	Excellent ^b	Excellent ^b	^c
Blind bolts ^d	A-286	Passivated	Excellent ^b	Excellent ^b	Excellent	^c
	Alloy steel	Cadmium	Not recommended ^b	Excellent ^b	Excellent	^c
Pull-type lockbolts	Titanium	None	Excellent ^e	Excellent ^f	Excellent ^f	Good or not recommended ^g
Stump-type lockbolts	Titanium	None	Excellent ^e	Excellent ^f	Excellent ^f	Good or not recommended ^g
Asp fasteners	Alloy steel	Cadmium/nickel	Good ^h	Excellent	Excellent	Excellent
Pull-type lockbolts	7075 Aluminum	Anodized	Not recommended	Excellent	Excellent	Not recommended

^aBlind rivets with controlled shank expansion.

^bMetallic structure on the backside.^[26]

^cPerformance in honeycomb should be substantiated by installation testing.

^dBlind bolts are not shank expanding.

^eUse flanged titanium collar.

^fFasteners can be used with flanged titanium collars or standard aluminum collars.

^gDepending on the fastener design, check with manufacturer.

^hNickel-plated Asp only.

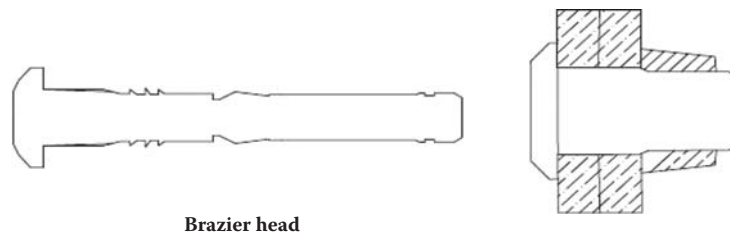

Fig. 3 Huckbolt fastener^[4]

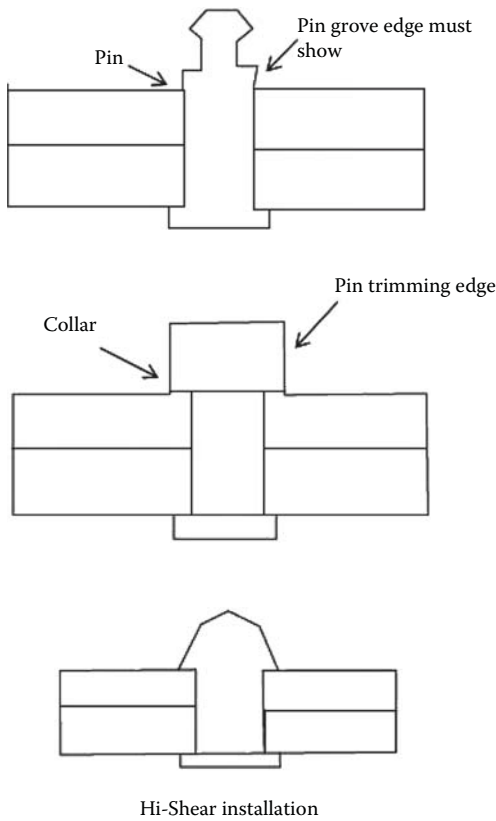

Fig. 4 Hi-Shear installation^[4]

together and to take advantage of the friction that exists between the two mating surfaces, hence not depending upon the shank properties. The other type depends purely upon the bolt shank strength. The most commonly used standards for bolt fasteners are American National, Unified, or the International System of Units (SI) (ISO metric) as shown in Fig. 6.^[25,26] ISO metric thread is the dominant standard (IS 4218-1976—in four parts) applied to threads. The designation for a coarse thread is by using the letter “M” followed by the nominal diameter of the bolt in mm, i.e., M6. The fine thread is also designated as the course thread, but with the additional introduction of the pitch in mm followed by the symbol “×,” i.e., M6 × 0.75.^[6,25]

When the fastener is tightened, there are compressive stresses that are exerted upon the respective faces of the material directly in contact with the bolt head under surface,

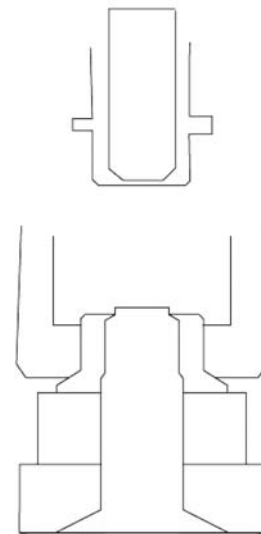

Fig. 5 The parts are pulled tightly together with the flanged collar over the pin. Collar locks in grooves and the pin breaks away^[4]

and also compressive stresses imposed upon the surface of the nut/washer in touch with the material being clamped. The torque is dependent upon the quality of the thread, plating/coating on fastener, lubrication, and the applied pressure. While it may be more direct to calculate the stiffness of fasteners, it becomes more complex when calculating the stiffness of the mating materials that need to be clamped together. The stiffness of a bolt is given as follows:

$$k_b = A \cdot E_b / l,$$

where k_b is the stiffness of the bolt, A is the nominal area, E_b is Young’s modulus of the bolt material, and l is the total thickness of the members joined as shown in Fig. 7. The stiffness of the gasket and the members also need to be determined; however, because the cone compressive area extends as shown in Fig. 7, it is difficult to determine the member’s stiffness.

The method to manufacture threads may be performed by one of two methods: cutting or rolling. Cutting is achieved via thread cutting machines that are called “screw” machines. Rolling is a forming method of bar stock into a threaded bolt. The advantages of bolts manufactured

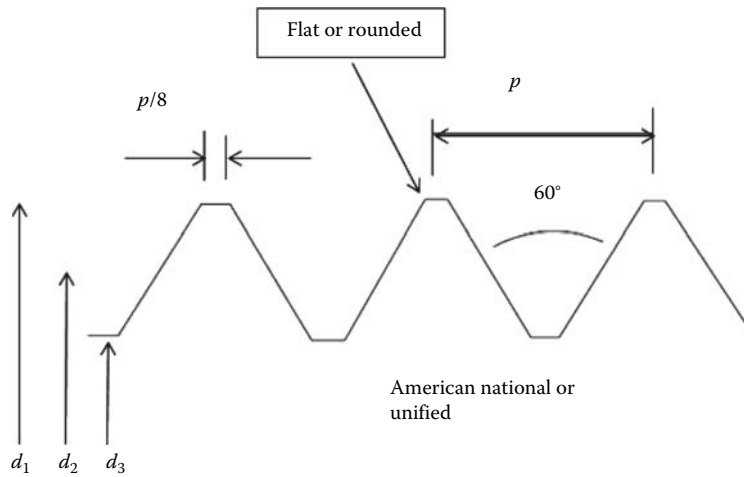

Fig. 6 Thread illustrating American National or Unified and SI^[25]

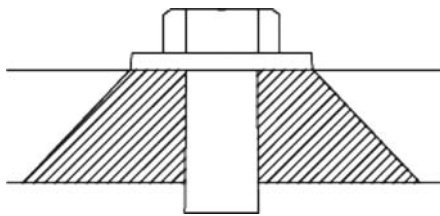

Fig. 7 Cone showing the compressive load area^[25]

from rolled bar as opposed to cutting are compressive residual stresses, which are introduced as a result of cold forming and rolling to achieve better mechanical properties in the threads such as improved strength and fatigue resistance. The cold forming creates blunting or radii at the root and the crest of the thread, thus reducing any stress concentrations. Bar stock are taken from forgings that have directional flow of lines, and the profile is selected so that these lines are parallel to the tensile loads and perpendicular to the shear loads.

MODES OF FAILURE IN BOLTS

Approximately 65% of bolt failures occur at the nut and bolt thread interface, at the thread ends (20%), or (15%)

under the bolt heads.^[25] These are due to the design of the bolts which inherently have stress raisers. If the design includes the fatigue stress concentration factor, then the failure can be avoided. For instance, if we refer to Fig. 8 to increase the capacity for the bolt to absorb shock, the design needs to include a rounded groove just after the threaded section of the shank, and it should be no greater than the diameter of the smallest diameter of the thread. Ideally, the most favorable bolt design would have stress levels being equally distributed at various cross sections.^[6]

Two modes of failure occur in bolts, and these are tensile in bolts and shear of the thread on the inside of the nut. Under tension, the bolt fails along the plane in the area of stress being applied. The tensile area of an unthreaded rod has been tested on threaded rods according to ISO.^[6] for comparative purposes. The diameters of the unthreaded rods such as the minor diameter (d_3) plus the pitch diameter (d_2) divided by two have the same tensile strength as that of the threaded rods. This is the region that is calculated for the purposes of bolt tensile strengths. The crests and roots of a thread may be either round or flat, and the reason for this is to minimize the stress levels in threads. Bolts have either coarse or fine threads, and the function of coarse threads is to reduce the static loads of the bolts while in service. Coarse threaded bolts do not

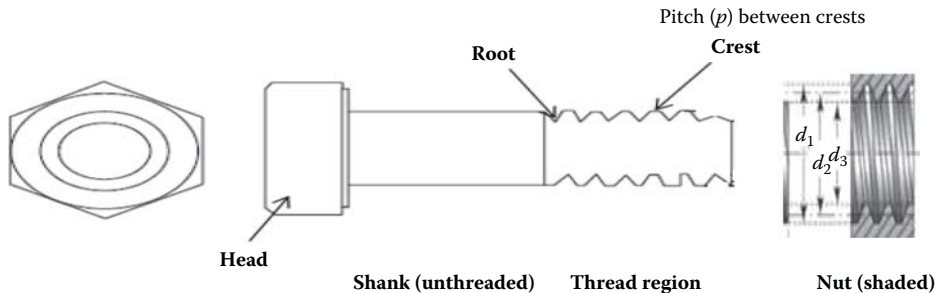

Fig. 8 Bolt design for increased shock absorption. d_1 = major diameter; $d_{crest} = d_1$; d_2 = pitch diameter; d_3 = smallest diameter; p = pitch (thread load applied equivalent to d_2)^[25]

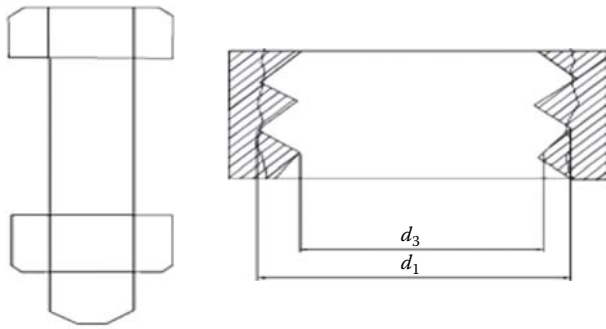

Fig. 9 Bolt and nut failure^[25]

easily seize while being tightened. Fine threads are stronger than coarse threaded bolts when alternating loads are imposed and are suitable for the components in service under dynamic loading and vibration. There is a larger effort or resistance in unscrewing fine threaded bolts.^[6]

The nut and bolt both have a load acting upon them as shown in Fig. 9, where the failure occurs at the root diameter. The thread shear area in a bolt is smaller than that in a nut, and for this reason, it has less material to contend with the shear forces and fails first. If the design stipulates that the bolt thread must not fail, then a safe height of the nut is calculated in order that shear failure is eliminated at the bolt thread.

The typical bolt design includes the consideration for a safety factor and material to be used. As a rule of thumb only, threaded fasteners, for instance, require a certain length of full thread engagement, and for aluminum, it is approximately two times the diameter of the fastener and one time the diameter for steel. The spacing between the bolts should not be more than six times the diameter.

PRELOADING OF BOLTS

When the nut is tightened after some free turning, the bolt is stretched and the bolt is placed in tension, and this is termed the preload. The preloading is based upon the torque being applied so that the bolt is stressed to 90% of the proof strength required for static loading and 75% of the proof loading for dynamic loading. If the tension of the bolt is maintained in the elastic range, then a clamping force is applied on the member joints, thus creating what is defined as a preload.^[25] The members subjected to compressive forces do so with the same magnitude that the bolt experiences the tensile force, that is if the members' stiffness is not ignored, and the members' stiffness needs to be higher than that of the bolt. The level of stretching in the bolt should be higher than the level of compressive movement of the members. That is, when the members joined have an applied load by torquing, the members are compressed together and clamped. Preloading assures a reduction in fluctuating stresses (remains inside the fatigue limit) and tighter joints, and minimizes or eliminates leaking.^[6,25]

EFFECT OF PLATING ON FASTENERS AT VARIOUS TEMPERATURES

Steel or carbon fasteners have good strength up to 55 ksi or 379 MPa, but poor corrosion resistance and high density and weight. Carbon steel can be surface treated with either zinc or phosphate to resist corrosion. Stainless steel fasteners are also commonly used for aerospace applications, and have excellent corrosion resistance and require no surface treatment. Their strengths range from 70 ksi or 482 MPa up to 220 ksi or 1516 MPa.^[4]

Cadmium plating is the most applied plating for aerospace fasteners, and it is baked at a controlled temperature/time to avoid hydrogen embrittlement. As stated prior, aluminum fasteners are not commonly used in aircraft. The main limitations of aluminum are strength and temperature capabilities compared to other materials such as steel alloys.

USE OF FASTENERS AND RIVETS IN THE CONSTRUCTION OF COMPOSITES

Rivets are not typically used for composites, because they expand while being installed with a rivet gun, and this can introduce delamination. The structural attachment design process is a major challenge in developing composite structures.^[37] The bolted joint is the weakest link in the structure.^[47] It is well documented that there is a reduction in the loading capacity of composites, because complicated stress fields adjacent to the holes occur; hence, the evaluation of failures in the joints is extremely challenging.^[23,46] Designing for composite mechanical fastening joints has been broadly based upon experimental data. Many groups have developed testing methods for mechanically fastened joints such as the National Aeronautical Space Administration and the Federal Aviation and Administration.

The literature shows that both glass and carbon epoxy composites were among the most widely studied materials, and that the experiments focused on the clearance between the hole and the pin, the degree of lateral clamping force exerted by pin or bolt, the stacking sequence, and the geometric properties.^[41] Some experiments have concluded that the larger the plate or the greater the width of the composite to the diameter of bolt, the greater is the bearing strength. Also, whether bearing strength increases with increasing preload and bearing strength is also dependent on the ply stacking sequence. Camanho and Matthews^[8] concluded in his review of the literature on fastened joints that the areas of research in stress analysis and strength predictions of mechanically fastened joints were not universally agreed upon as to how to appropriately predict the type of failure mode.

Failure modes for fastener joints are shown in Fig. 10.^[11,24] Some important bearing capability considerations are lateral constraint, single shear lap joints, and countersunk holes. Lateral constraint helps to reduce the buckling fibers

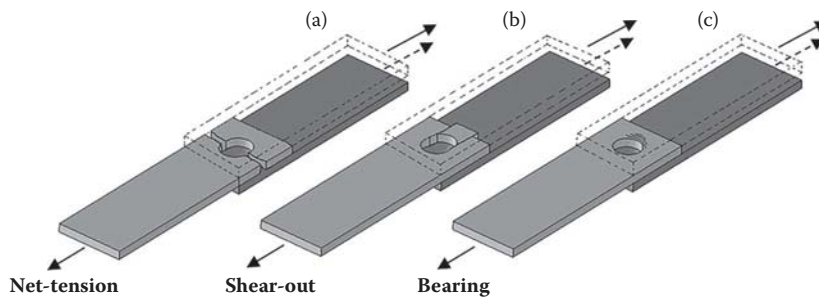

Fig. 10 Failure modes of fastener joints in composite plates: (a) net tension; (b) shear-out; (c) bearing failure^[11,41,47]

in the composite, thus providing a higher bearing stress.^[14] There is a decreased bearing strength when there are countersunk holes because complex three-dimensional stress fields exist in the vicinity of the hole, and this is much more pronounced than that for flat surface-aligned holes.^[12]

Since composites are brittle, and unlike metals such as aluminum which is typically used in aircraft, they show little or no signs of deformation. It is clear then that underneath the composite surface layer, there could be instances of damage where the surface has had some impact upon it. If there is damage beneath the surface, then there could be extended periods of time whereby this damage is not detected at all, and eventually leads to failure.

The restrictions mentioned previously in this section with regard to mechanical fastening in composites, combined with degradation of composites at high temperatures,^[10,38] the hygrothermal effects in composites makes the picture even more complex! The field in composites, in particular with respect to mechanically fastened joints, requires yet much more research and study in a more systematic way before any real confidence can be stipulated in the design of aircraft assembly.

Of major concern reported throughout the literature is that fasteners provide a chief conduction pathway for lightning currents (up to 200,000 amps in fasteners), which stem from the skin of the aircraft and make its way into the ribs and spars and poor fasteners arcing or sparking from lightning strikes. Figure 11 shows a fastener sparking. The greatest fear is due to fastener arcing; this could cause lightning near the composite fuel tank as this may cause hot debris (gas or particle) to be ejected due to the fastener

being struck and could lodge itself into the fuel tank creating a catastrophe. To protect against lightning current, one method is to use metal (aluminum, copper, or bronze) mesh near the surface of the composite while being manufactured. Commonly, the mesh used to cover the composite is on the surface and is called the bolt-line. The bolt-line mesh increases the area of metal for each fastener, thereby enhancing electrical continuity/current dispersion and reducing the risk of the fastener sparking. Secondary structures such as tail cones, wing tips, and flight controls generally do not have the quantity of fasteners to enable transfer of lightning currents.^[44] This results in further damage to material in the vicinity including other fasteners.

Another source of problem occurs when holes are drilled into the composite structure, and the holes actually create a barrier for the flowing current throughout the composite structure and thus serve as a site for an increased current path.^[44] Defects may be present as a result of the drilling such as fiber pullout and exit delamination. These defects are denoted as machining-induced effects.

Fasteners for composites ideally should have large heads in order that the loads are distributed over larger areas to avoid crushing. Damage to the composite can be done if the correct drill bits are not used. When the cutting tool wears, more surface chipping, more fiber fractures, fiber pullout, and exit delamination.^[20] If the hole is too large as mentioned previously, then this will cause oscillating shear loads or fretting, and to overcome this problem, a simple but not highly recommended procedure is to bond the fasteners in place with adhesives. When composites are cut, their fibers are exposed.

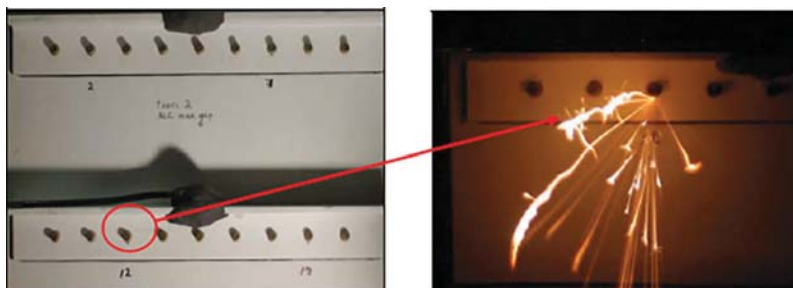

Fig. 11 Sparking of fastener

GALVANIC CORROSION DUE TO ALUMINUM FASTENER-COMPOSITE CONTACT

The corrosion of aluminum occurs when it is in contact with carbon fiber-reinforced composites. Tests with salt sprays or with natural environment illustrate that corrosion is harsh.^[7] In an aircraft, the carbon composite control surfaces such as the aileron and elevator may have aluminum hinge fittings connected to them, thus creating a strong potential for galvanic corrosion. Therefore, in aircraft the carbon composite is cathodic, and it is in contact with the smaller components such as metal bolts and rivets, for instance, and are anodic. The small anode (aluminum rivet/bolt/fastener/nut) to large cathode (carbon composite) accelerates the corrosion. Therefore, aluminum fasteners connecting carbon composite must be avoided if the fibers are in direct contact with aluminum, by using titanium (closer to graphite in the electrochemical series). Titanium alloy (Ti-6Al-4V) is the typical fastener that is used for carbon fiber composites. Another method to eliminate galvanic corrosion is to use glass fabric electrical insulation layer between aluminum and carbon fiber composite.^[9] Boeing 777 utilized an aluminum splice channel in order to avoid the direct contact between the carbon composite floor beam and the primary structural frame.^[29]

FASTENER RIVETS AND BOLTS SUBSTITUTED FOR WELDING OF METALS IN AIRCRAFT

LBW utilizes a solid-state or gas laser as a high-power density to melt locally a filler wire which is situated between the two work pieces to be joined. Shielding gas such as argon mixed with helium provides a good mix to shield the fusion joint from impurities in the air that may enter. This eliminates or reduces hot cracking and porosity, which are some of the undesirables of LBW. The reduction in hot cracking can be achieved by reducing the hydrogen solubility in the HAZ, and certain alloys can be chosen to reduce solidification cracking also.^[36] Other disadvantages include reduced strength in the HAZ. LBW was used in the A380 to attach stringers to the bottom section of the fuselage skins. The process involves welding approximately 8 m in about a minute, and this has been in use since 2001 to connect the lower skins of the fuselage in the A318.^[42] Welding decreases the weight when substituted for rivets but increases the shear and compressive stresses as opposed to using rivets. The reduction of the overall weight of the aircraft actually translates into approximately 10% of weight savings in stringer panels used below the main deck floor in the A380.^[40]

This removes not only rivets but also the possibility of corrosion and many other adverse properties including fatigue cracking that have been the result of rivets. The stringer and skin connection are not riveted as a result of the LWB taking its place, and it is performed at much reduced

construction costs. Laser welding is beneficial in that it reduces the HAZ in metals, produces deep penetrations, and can join dissimilar metals without creating cracking. It is simpler to join materials together by butt joining and eliminate thousands of rivets and adhesives. The substitution of rivets for LBW or FSW is one of the processes that can reduce corrosion, weight, and cost, to name a few of the advantages. Corrosion is reduced or eliminated via these welding processes because single components replace panels that traditionally overlap one another by riveting, which has a propensity to retain moisture and corrosive products, thereby ultimately causing failure. Additionally, the problems associated with rivets and their respective holes are eliminated. Joints generally contribute to a myriad of types of stresses also, and they increase production costs. However, it is also impossible to construct very large panels from the perspective of manufacturing costs and maintenance because it is impractical when changing parts. Therefore, the three typical joining processes to date have been the use of fasteners, bonding, and welding.

Similarly, FSW can be used to weld panels, and the advantages include weight savings, reduced drilling of holes, and faster joining (Fig. 12). The materials being joined do not reach their melting point temperature, which is important to maintain a certain level of strength in the alloys.^[32] As a result, the jet Eclipse 500 eliminated thousands of rivets and fasteners.^[13,28,32] The process involves a tool that is not a consumable to weld by the process of friction and heating locally. The tool rotates and imparts heat to the metal and produces a solid-state weld. The tool is generally in the shape of a solid cylindrical shape, like a pin or rod with a concave section on the cylindrical tool connecting to the workpiece to be joined, and the workpieces are joined by clamping and supported by a backing plate.

ENDURANCE AND INTEGRITY OF AIRCRAFT COMPONENTS

The Corrosion Prevention and Control Program is the typical reference point in the aircraft industry. Therefore, there has clearly been a lack of education in relation to corrosion and how to counteract this through specific design, not only in aircraft but in almost all designs.^[22]

Many aging United States Air Force aircraft have been found to exhibit several structural degradation aspects such as pitting, exfoliation, corrosion, stress corrosion cracking, fatigue, lack of bonding, and delamination.^[21] Due to failure to adequately describe the corrosion once found in a fixed wing or rotary wing aircraft, while still in the primary stages of design, the consequence has proved to be dire. Pitting and crevice corrosion are most common in 2000 and 7000 series aluminum alloys.^[16,29] Crevice corrosion cannot be seen when it occurs as it exists in the base of the crevice, and it cannot be seen as it is progressing,

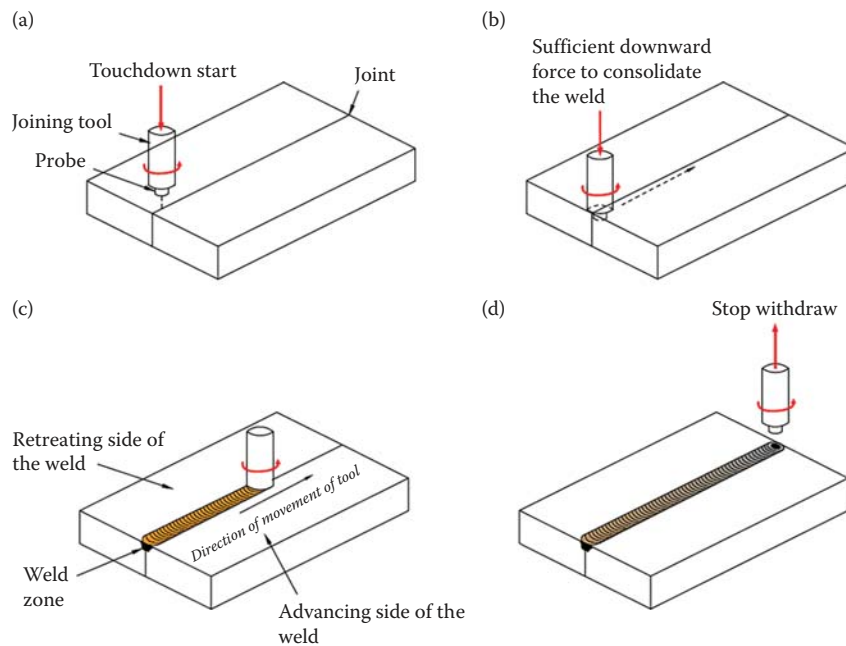

Fig. 12 Schematic showing FSW: (a) commence welding; (b) force down to consolidate; (c) weld is advancing; and (d) completion of weld and withdrawal of tool

thus making it a lot more severe than pitting corrosion.^[16] Crevice corrosion has been found in certain aircraft in lap joints. The reason for this was speculated to be more likely due to moisture occurring as a result of condensation solution being trapped near the fastener heads, thus forming a galvanic couple. As a result, the grains were compromised via intergranular attack, further developing into exfoliation.^[19] This type of corrosion typically occurs in regions within grains that are not protected, such as in rivet holes or plate ends.^[15]

Energies that exist within grain boundaries are much higher than energies that exist within the grains, and for this reason, stresses are greatly increased when the load is applied normal to the grain boundaries, thus inducing stress corrosion cracking.^[1,3,17,29,33] High-strength aluminum alloys 2000 series and 7000 series^[27] exhibit grain boundaries that are elongated in the rolling direction, which makes them more susceptible to preferential corrosion. Since the 7000 series has copper and zinc among its principal elements, it is these very elements that gather at grain boundaries and leave certain sites free from precipitates. Aluminum is anodic in comparison with the copper in the galvanic series; hence, its reaction causes the grain boundaries to preferentially corrode, also known as intergranular attack. Generally, in the 2000 series, the 2024-T3 is used for skins, and in the 7000 series, 7075-T6 is used for stringers and frames.^[2] 2117-T4 is among the most widely used rivets in aircraft, but it is only used where there are lower strength requirements. The upper wings in subsonic aircraft utilize 2024-T4 because they are better in compression, whereas

the lower wings utilize 7075-T73 as they are better in tension.^[35] The 2000 series alloys are designed to be clad; otherwise, they will undergo intergranular corrosion. However, cladding effectively decreases the fatigue properties of mechanically fastened or riveted joints.

Crevice corrosion is one of the most common and sinister types of corrosion that exists, because it typically sets in the joints that overlap one another, particularly in the fuselage where moisture can sit in the crevice geometries for long periods, thus creating localized attack. Crevice corrosion does not only take place between metal joints only but may occur also between a metal and nonmetal. It is in lap joints, e.g., in the fuselage, where the oxygen potential is at its lowest and becomes a hidden form of corrosion (Fig. 13). Regions within metals have different electrochemical potentials to one another, and the energy may exist in the form of chemical and electrical potential energies. The base of the crevice is anodic and the mouth is cathodic, thus producing oxidation. The anodic reaction (oxidation) sections lose electrons, $M \rightarrow M^+ + e^-$, and the cathodic reaction (reduction) sections gain electrons, $2H^+ + 2e^- \rightarrow H_2$.

Basically, any surface on a metal that is not exposed to the atmosphere (oxygen) will be unable to build an oxide layer to protect itself against corrosion. When an oxygen-deprived region is formed such as a pit in a metal, and in the presence of stagnant or stationary water, for instance, the metal ions are released from the metal within this pit and travel away from the pit and into the surrounding droplet/film of water. The surface of the metal may dry out, or the cathodic or oxidation reaction on the metal surface takes place and protects

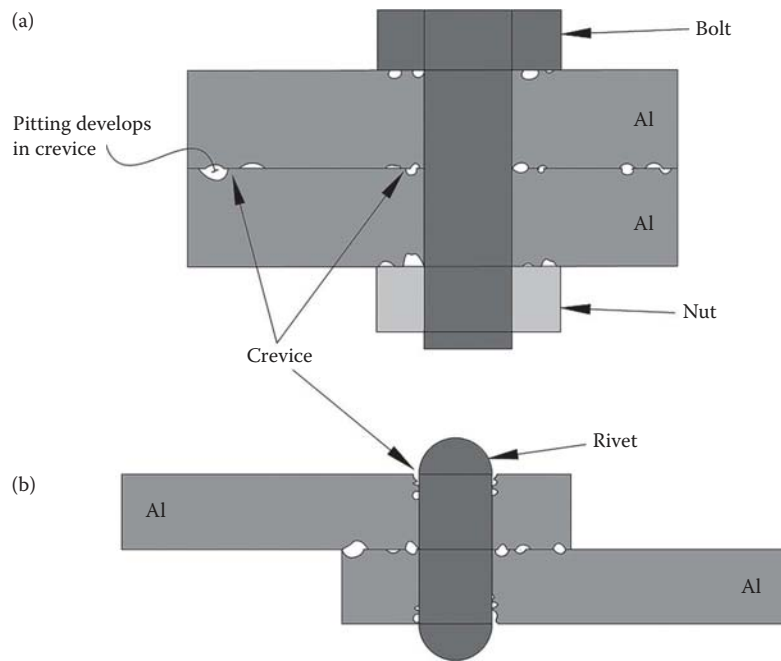

Fig. 13 Illustration of typical crevice corrosion: (a) aluminum sheets connected by bolt; (b) sheet connected by rivet

the metal due to excess oxygen present. These localized types of crevices are more menacing in nature than other types of corrosion such as uniform corrosion, because the sites are covered and not detected easily. The corrosion as a result can be extremely rapid because the metal ions from the cavity travel outward and react with the hydroxide ions forming corrosion (rust) at the mouth of the crevice. This action further prevents oxygen from migrating into the crevice/pit, thus enlarging the cathodic area to this anodic region, making corrosion much worse.

The famous Aloha Airline incident in 1988 illustrates the problem with crevice corrosion in the fuselage. The airliner was a 19-year-old Boeing 737 aircraft, and it was operated by Aloha. The airliner lost a major portion of the upper fuselage near the front of the plane in full flight at 7300 m altitude.^[34] The extent of damage is shown schematically in Fig. 14 and a photograph of the actual damage in Fig. 15. Several fatigue cracks also were found in the remaining aircraft, and in holes in the upper row of rivets of the lap joints in the fuselage.

Fatigue cracking would not have been an issue had the bonding remained intact. The adhesive cold bonding was the method for joining the skin panels, and fasteners or rivets were used along with this bonding technique in order that surface contact was achieved. This method allowed the bonding adhesive to transfer the loads between skin panels. Although the adhesive was breaking down, corrosion was setting into the joints and this resulted in the final debonding, thus causing the fasteners to carry the balance of the loading for which they originally were not intended for. The pressurization of the cabin was repeated, which meant that the cycles ultimately led to cracks forming at the fastener holes. The aircraft was continually subjected to pressurization on every flight as the cabin is pressurized after takeoff in order that passengers are able to breathe an atmosphere, which is similar to that close to sea level. The air actually gets thinner as the altitude is increased. The cabin is depressurized as the aircraft is reducing in altitude, and there is very high exposure of corrosion due to excessive saltwater in proximity at most times. Thus, all



Fig. 14 Schematic description of the Aloha aircraft incident



Fig. 15 Damage caused as a result of crevice corrosion in the fuselage of the Aloha Airlines Flight 737^[44]

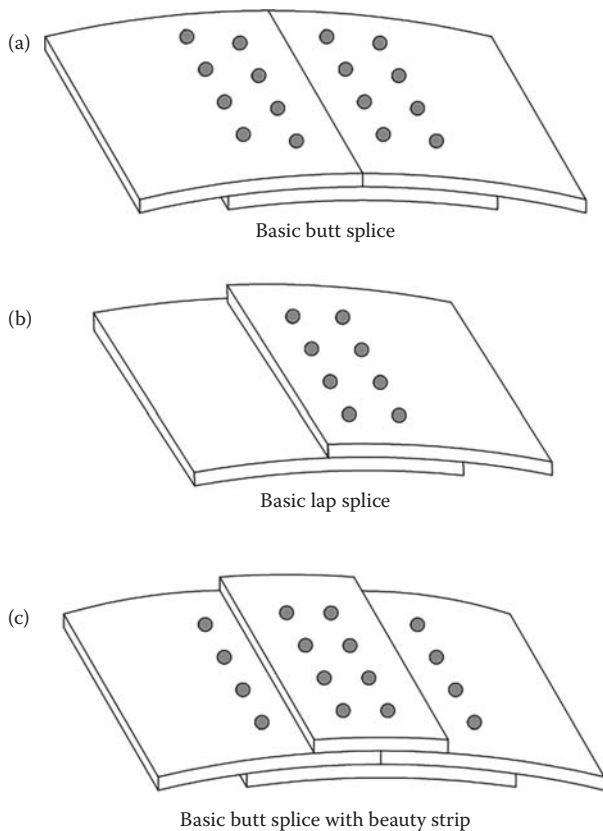

Fig. 16 Three basic types of lap splices used for construction of aircraft fuselages

of the above resulted in multiple site–metal fatigue damage. The multiple site damage was a result of the forming and linking up of fatigue cracks formed in the vicinity of the rivet holes. However, lack of experienced inspectors maintaining the aircraft also did not help because the maintenance checks were inappropriate.

There are three basic types of aircraft fuselage lap splices, and these are shown in Fig. 16. A fuselage typically integrates two or three different types of splicing. Certain manufacturers either rivet or seal the lap joints, whereas other manufacturers rivet and use adhesive bonding.^[31] The main problem with the Aloha incident, as

mentioned previously, was that the panels in the fuselage that were overlapping one another would not have failed if the bonding had held them together firmly.^[45] Corrosion inside lap joints commonly referred to as crevice corrosion leads to a buildup of voluminous corrosion products inside the lap, resulting in a pillowing effect, which is highly undesirable and creates an extremely dangerous condition. The overlapping surfaces separate, as shown in Fig. 17. The corrosion product in the fuselage joints is referred to as aluminum oxide trihydrate and has an increased volume expansion relative to aluminum, as shown in Fig. 18. This buildup of voluminous corrosion products also creates an undesirable increase in stress levels near critical fastener holes. It is common for rivets to fracture due to high tensile stresses which result from pillowing.^[30] Studies have shown that an increase in volume of corrosion buildup in a joint also results in an increased level of stress, and this increase in stress level therefore is not only dependent upon the sectional thickness loss due to corrosion.^[30] This type of corrosion—pillowing in lap splices—is causing immeasurable damage in both commercial and military aircraft, and this is more so predominant in aging aircraft.

The aluminum oxide trihydrate is insoluble and tends to remain in position in the joints, hence forming the bulging or pillowing effect within the skins.^[5] Depending upon the location of pillowing, it was found that generally as pillowing increases, the stress intensity increases for the crack edge along the faying surface, resulting in rapid growth of faying surface cracks. In rivet regions on the outer surfaces, however, experiencing compressive stresses, as opposed to tensile stresses, there seems to be a reduced growth of faying surface cracks.^[5]

Because aircraft material generally require joining between one and another, it is often difficult to analyze precisely the stresses in riveted sections. However, assumptions, large safety factors, and experience combined yield overall safer designs. A lap joint indicating two plates connected via rivets or bolts is shown in Fig. 19. This is one of the simplest joints used in construction. The distance between each of the rivets along a row is known as the pitch, and the distance between the rows of rivets is known as back pitch, transverse pitch, or gauge.

A rule of thumb for applying the pitch distance in aluminum or steel plates is three times the diameter of the rivet or bolt, and the minimum edge pitch closest the rivet adjacent the edge is one and half times the rivet or bolt diameter. If the assumption is to apply edge loads, and that the rivets are of a particular diameter and are at a certain distance away from one another, and also that the distance from the location of the rivets is a certain distance from each of the plates, then there can be three possible types of failure modes: (1) rivet shear, (2) rivet/plate bearing failure, and (3) net section failure, and these will be described next.

Rivet shear: The rivet or bolt as shown in the side view of Fig. 20 is placed in shear. The calculation for the shear

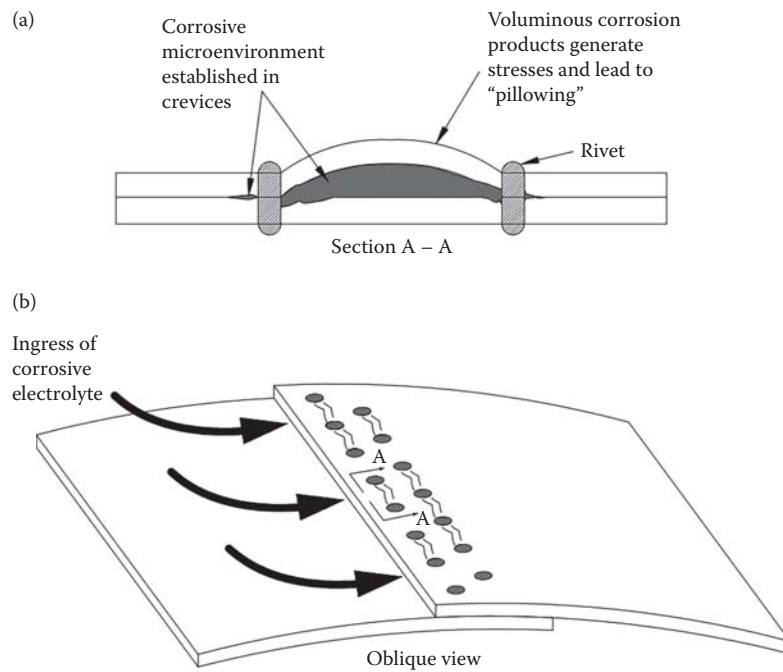

Fig. 17 Pillowing of lap splices in aircraft

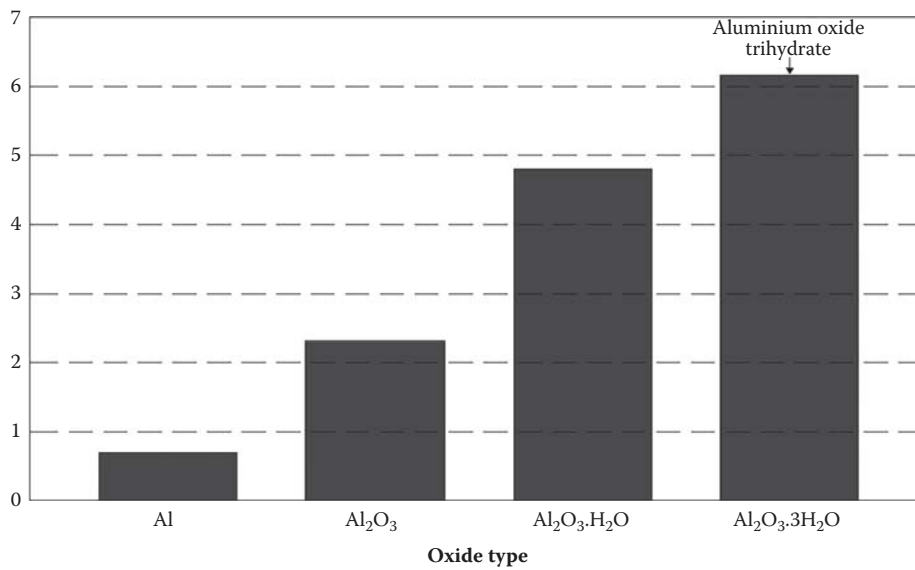

Fig. 18 Relative volume of aluminum corrosion products

stress is the force applied that is parallel to the area in shear and divided by the area.

The rivets or bolts may fail across their diameters as shown in Fig. 20 at the plate joint location, and the formula is represented as follows:

$$P_{\text{rivet shear}} = N \left(\frac{1}{4} \cdot \pi d^2 \right) \tau_{\text{all}}$$

where:

$P_{\text{rivet shear}}$ = Shear strength of the riveted or bolted system

N = Number of rivets or bolts in shear (in a lap joint with one cover plate)

$\pi = 3.1415$

d = Diameter of the rivet or bolt

τ_{all} = Allowable shear stress for rivet or bolt

Rivet/plate bearing failure: Either the rivet or plate material behind the rivet will fail in compression.

Fig. 21 shows an elevation view of the plates with a rivet holding them together. When the loads are applied to the plates, it can be seen in the plane view in the schematic

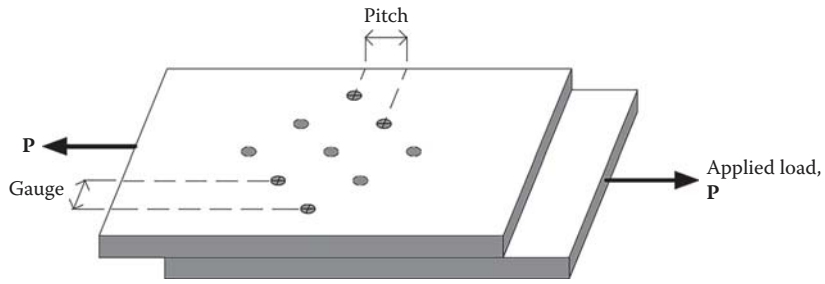

Fig. 19 Lap joint showing rivets or bolts penetrating through two plates and connecting them together

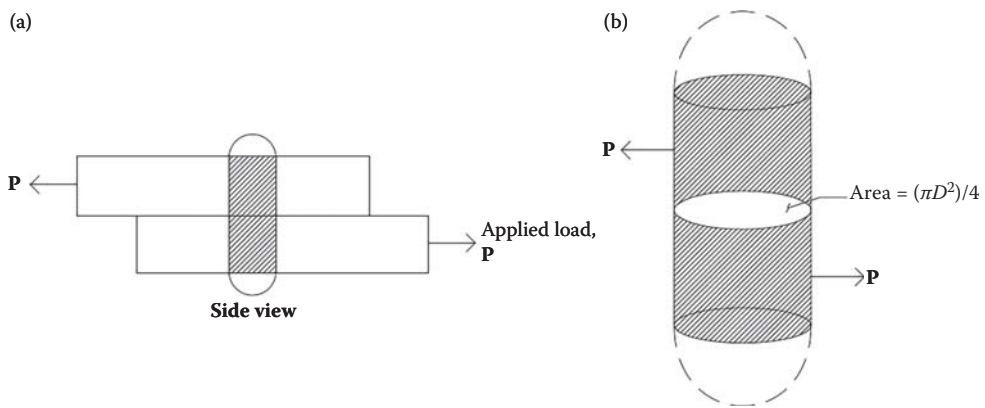

Fig. 20 Side view of lap joint showing forces applied parallel to the area in shear

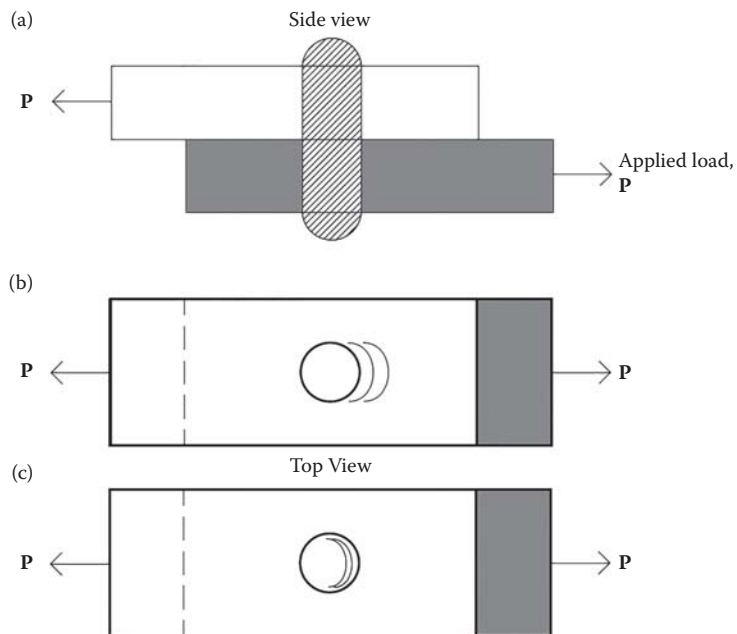

Fig. 21 Illustration showing (a) section, (b) compression into sheet adjacent hole, and (c) compression being induced upon the rivet due to the top plate being pulled into the rivet

that the top plate is actually pulled into the rivet. The plate behind the rivet is therefore in compression. In either case, depending upon several factors including the compressive stress allowable for either the rivet or the plate, either the rivet or plate may fail in compression.

The areas of the plate and rivet being under compression and the vertical cross-sectional area of the rivet where the area of the plate contacts the rivet is placed in compression are shown in Fig. 22.

The area under shear stress multiplied by shear stress is considered to be the load that determines the cause of failure. Therefore, generally, the area in compression along with the vertical cross-sectional area of the rivet are considered to be the area of the rivet in compression and also the area of plate in compression.

$$P_{\text{bearing}} = N(d \cdot t)\sigma_{\text{All}}(c)$$

where:

P_{bearing} = Compressive strength of the riveted or bolted system or plate

N = Number of rivets or bolts in compression

d = Diameter of the rivet or bolt

t = Thickness of the plate

$\sigma_{\text{All}}(c)$ = Allowable compressive stress for the rivet or bolt or plate

Net section failure: The rivet row locations generally permit a failure of the plate when the plate is in tension; thus, tensile failure occurs first at the hole locations in the plate. If the plate material is cut at the first rivet row location, then the plate material is in tension. To determine the load, the plate can withstand before failure in tension occurs; the area that is placed under tension is multiplied by the allowable tensile load or stress. The area is typically the cross-sectional area of the plate. Because the plate is torn at the rivet locations, the diameter of the

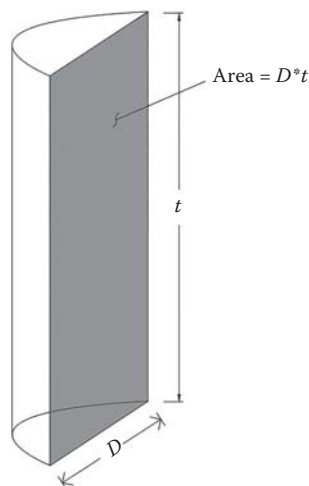

Fig. 22 Region of compression in the regions of plate and rivet, typically considered to be the vertical cross section of the rivet

rivets must be deducted from the width of the plate, as the area of the plate is reduced by the rivet holes. Calculations for rows beyond the first row are a little more detailed and not intended for the scope of this article. However, the rows beyond row 1 actually carry less loading than the first row as some of the loading is transferred to the next plate:

$$P_{\text{1st Row}} = (w - d \cdot n)\sigma_{\text{All}}(t)t$$

where:

$P_{\text{1st Row}}$ = Tensile strength of plate at the first rivet row

w = Width of the plate

d = Diameter of the rivet

n = Number of rivets in a row

$\sigma_{\text{All}}(t)$ = Allowable tensile stress on the rivet or plate

t = Thickness of the plate

CONCLUSION

Fasteners for structural applications are not only dependent upon their own properties but are also very much dependent upon the structures to which the fasteners are connected. It is a holistic approach, when considering design for mechanical joints. All materials must be examined on a micro and a macro level, and design philosophies such as “damage-tolerance” and “fail-safe” are necessary to take into account with structures adjacent and in connection with any fasteners, bolts, or rivets. Fastener design alone is not enough, nor is it simple to design, because many factors must be taken into account to ensure longevity so that it is fit for purpose. Preloading of bolts is a requirement in design, but this also depends upon the stiffness of the metal or composite, and then there is the plating or coating on the fastener that must withstand certain temperatures; otherwise, hydrogen embrittlement and other issues contribute to the degradation of the fastener. Increase in temperature or skin friction effects in the aircraft creates drag whereby further design is required to control the level of drag and maintain material integrity. Galvanic corrosion is the largest problem only if dissimilar metals and or graphite fiber is in contact with aluminum material, but this can be eliminated by removing aluminum and substituting with titanium or placing a suitable protective glass barrier between the two materials. The replacement of rivets and fasteners for welding has been successful with the use of LBW and FSW as many of the mechanical properties are also improved, but also there are some disadvantages in these methods, and the benefits must be weighed against these nonbenefits in every situation. Because aluminum sheets are still commonly used in many aircraft, and they mostly comprise of riveting, some corrosion is almost inevitable in these structures and must be assessed on a regular basis, as the crevice or pitting type of corrosions do not give much notice and are not detected without effort.

From the literature reviewed, it was also evident that in order to gain a credible understanding of fasteners, bolts, and rivets, all of the materials in an aircraft that require joining would need to be assessed not only on a macroscopic level but also on a microscopic level. It would appear firsthand that the design for fasteners, bolts, and rivets for use in aerospace structures would not at all be difficult. Unfortunately, this is not the case, and as discussed throughout this article, these items require a more pragmatic and empirical approach to designing suitable connections for a diverse range of materials. That is, whether the material is a metal or a composite component or a combination of both requiring to be joined, these components need to be assessed in greater detail so that the final design is not dictated solely by the mechanical joint. The countless variables similar to those discussed throughout this article, although only limited, must all be taken into account. Incorrect designs and/or the absence of data and environmental factors, temperature, initial preload, fatigue, metal and composite galvanic corrosion, orientation of fibers, hidden corrosion in metals, and so on to choose the type of fastener required are essential for appropriate design.

REFERENCES

- Altenpohl, D.G. *Aluminum: Technology, Applications, and Environment: A Profile of a Modern Metal*, Aluminum Association, Inc., Washington, DC and the Minerals & Metals Society: Warrendale, PA, 1998.
- Arriscorreta, C.A.; Hoepfner, D.W. Exfoliation corrosion and pitting corrosion and their role in fatigue predictive modeling: State-of-the-art review. *Int. J. Aerosp. Eng.* **2012**, *2012*, 29.
- Banis, D.; Marceau, J.A.; Mohaghegh, M. Design for corrosion control. *Aero Magazine* no. 8, **1999**.
- Barrett, R.T. *Fastener Design Manual*; NASA Reference Publication, 1990.
- Bellinger, N.C.; Komorowski, J.P.; Gould, R.W. Damage tolerance implications of corrosion pillowing on fuselage lap joints. *J. Aircraft* **1997**, *3*, 317–20.
- Bhandari, V.B. *Threaded Joints. Design of Machine Elements*; Tata McGraw Hill Education Private Limited: New Delhi, 1994.
- Brown, A.R.G. Corrosion of carbon fibre reinforced plastic to metal couple in saline water. *Plast. Polym.* **1974**, *35*, 230–241.
- Camanho, P.P.; Matthews, F.L. Stress analysis and strength prediction of mechanically fastened joints in FRP: A review. *Compos. Part A* **1997**, *28A*, 529–547.
- Campbell, F.C. *Structural Composite Materials—Environmental Degradation. Environmental Degradation*; ASM International: Materials Park, OH, 2010.
- Chamis, C.C.; McManus, H.L. *Stress and damage in polymer matrix composite materials due to material degradation at high temperatures*. NASA, 1996.
- Chang, F.K.; Scott, R.A.; Springer, G.S. Strength of mechanically fastened composite joints. *J. Compos. Mater.* **1982**, *16*, 470–494.
- Chishti, M.; Wang, C.; Thomson, R.; Orifici, A. Experimental investigation of damage progression and strength of countersunk composite joints. *Compos. Struct.* **2012**, *94* (3), 865–873.
- Christner, B.; McCoury, J.; Higgins, S. Development and testing of friction stir welding (FSW) as a joining method for primary aircraft structure. In *Fourth International Symposium on Friction Stir Welding*, Park City, UT, May 14–16, 2003.
- Collings, T.A. The strength of bolted joints in multidirectional CFRP laminates. *Composites* **1977**, *8* (1), 43–55.
- Engineers, Institution of Mechanical Engineers (Great Britain); Royal Aeronautical Society; Institution of Electrical. *Aeroengines and propulsion: Selected papers from Aerotech 95*. IMechE Seminar Publication, 1996.
- Flower, H.M. *High Performance Materials in Aerospace*; Springer Science & Business Media: Dordrecht, the Netherlands, 1995.
- Fontana, M.G. *Corrosion Engineering*; McGraw Hill Book Co.: New York, NY, 1986.
- Gerlach, R.; Siviour, C.R.; Wiegand, J.; Petrinic, N. In-plane and through-thickness properties, failure modes, damage and delamination in 3D woven carbon fibre composites subjected to impact loading. *Compos. Sci. Technol.* **2012**, *72* (3), 397–411.
- Groner, D.J.; Nieser, D.E. U. S. Air Force aging aircraft corrosion. *Can. Aeronaut. Space J.* **1997**, *42* (2), 63–67.
- Hocheng, C.C.; Tsao, H. Computerized tomography and C-scan for measuring delamination in the drilling of composite materials using various drills. *Int. J. Mach. Tool. Manuf.* **2005**, *45* (11), 1282–1287.
- Hoepfner, D.W. Parameters that input to application of damage tolerance concepts to critical engine components. In *Proceedings of the AGARD Conference Damage Tolerance Concepts for Critical Engine Components*; San Antonio, TX, 1985a.
- Hoepfner, D.W. Pitting corrosion: Morphology and characterization. *Framework* **1985b**, *25*, 26.
- Icten, B.M.; Sayman, O. Failure analysis of pin-loaded aluminum–glass–epoxy sandwich composite plates. *Compos. Sci. Technol.* **2003**, *63* (5), 727–737.
- Jadee, K.J. Progressive failure analysis and failure map into plain weave glass fibre reinforced polymer bolted joint. *Am. J. Mater. Sci. Eng.* **2015**, *3* (2), 21–28.
- Jadon, V.J.; Verma, S. *Design of Threaded Fasteners. Analysis and Design of Machine Elements*; I. K. International Publishing House: New Delhi, 2010.
- Jensen, W.J. Failures of mechanical fasteners. *Met. Handb.* **1986**, *11*, 529–549.
- Jones, D.A. *Principles and Prevention of Corrosion*; Macmillan: New York, 1992.
- Kemal, K.M.; Aydin, Ş.; Kaluç, E. Effects of tool rotation and pin diameter on fatigue properties of friction stir welded lap joints. *Int. J. Adv. Manuf. Technol.* **2008**, *36* (9), 877–882.
- Koch, G.H.; Brongers, M.P.H.; Thompson, N.G.; Virmani, Y.P.; Payer, J.H. *Corrosion Costs and Preventive Strategies in the United States*, 2001.
- Komorowski, J.P.; Bellinger, N.C.; Gould, R.W.; Marincak, A.; Reynolds, R. Quantification of corrosion in aircraft structures with double pass retroreflection. *Can. Aeronaut. Space J.* **1996a**, *42* (2), 76–82.

31. Komorowski, J.P.; Krishnakumar, S.; Gould, R.W.; Bellinger, N.C.; Karpala, F.; Hageniers, O.L. Double pass retroreflection for corrosion detection in aircraft structures. Paper presented at the *AGARD Proceedings*, 1996b.
32. Lohwasser, D.; Chen, Z. *Friction Stir Welding*; Woodhead Publishing: Boca Raton, FL, 2009.
33. Marceau, J.A.; Caton, R.G. Corrosion control and prevention on aging commercial aircraft. Paper presented at the *Proceedings of the 1989 Tri-Service Conference on Corrosion*, Atlantic City, NJ, 1989.
34. Miller, D. Corrosion control on aging aircraft: What is being done. *Mater. Perform.* **1990**, *29*, 10–11.
35. Mouritz, A. *Introduction to Aerospace Materials*; Woodhead Publishing Limited: Oxford, 2012.
36. Norman, A.F.; Hyde, K.; Costello, F.; Thompson, S.; Birley, S.; Prangnell, P.B. Examination of the effect of Sc on 2000 and 7000 series aluminium alloy castings: For improvements in fusion welding. *Mater. Sci. Eng. A* **2002**, *354* (1–2), 188–198.
37. Okutan, B. The effects of geometric parameters on the failure strength for pin-loaded multi-directional fiber-glass reinforced epoxy laminate. *Compos. Part B-Eng.* **2002**, *33* (8), 567–578.
38. Parhi, P.K.; Bhattacharyya, S.K.; Sinha, P.K. Hygrothermal effects on the dynamic behavior of multiple delaminated composite plates and shells. *J. Sound Vib.* **2001**, *248* (2), 195–214.
39. Polmear, I.J. *Metallurgy of Light Metals*; Edward Arnold: London, 1995.
40. Rendigs, K.H.; Knwer, M. Metal Materials in Airbus A380. In *2nd Izmir Global Aerospace and Offset Conference*; Gaziemir-Izmir, 2010.
41. Sen, F.; Pakdil, M.; Sayman, O.; Benli, S. Experimental failure analysis of mechanically fastened joints with clearance in composite laminates under preload. *Mater. Des.* **2008**, *29*, 1159–1169.
42. Simons, G.M. *The Airbus A380*; Pen & Sword: Barnsley, 2014.
43. Fisher, F.A.; Plumer, J.A. *Aircraft Lightning Protection Handbook*; Federal Aviation Administration U.S. Department of Transportation, 1989.
44. Washington, National Transportation Safety Board Bureau of Accident Investigation. Aircraft accident report – Aloha Airlines, Flight 243, Boeing 737-200, N 737 111 near Maui, Hawaii. In *NTSB/AAR-89103: National Transportation Safety Board Bureau of Accident Investigation*, June 4, 1989.
45. Wildley, J.F. Aging aircraft. *Mater. Perform. Mag.* **1990**, *80*.
46. Wu, T.J.; Hahn, H.T. The bearing strength of e-glass/vinyl-ester composites fabricated by Vartm. *Compos. Sci. Technol.* **1997**, *58* (9), 1519–1529.
47. Yy'lmaz, T.; Sy'nmazçelik, T. Investigation of load bearing performances of pin connected carbon/polyphenylene sulphide composites under static loading conditions. *Mater. Des.* **2007**, *28*, 520–527.